

# FlytProf-Lite

## Free-Flight Controller

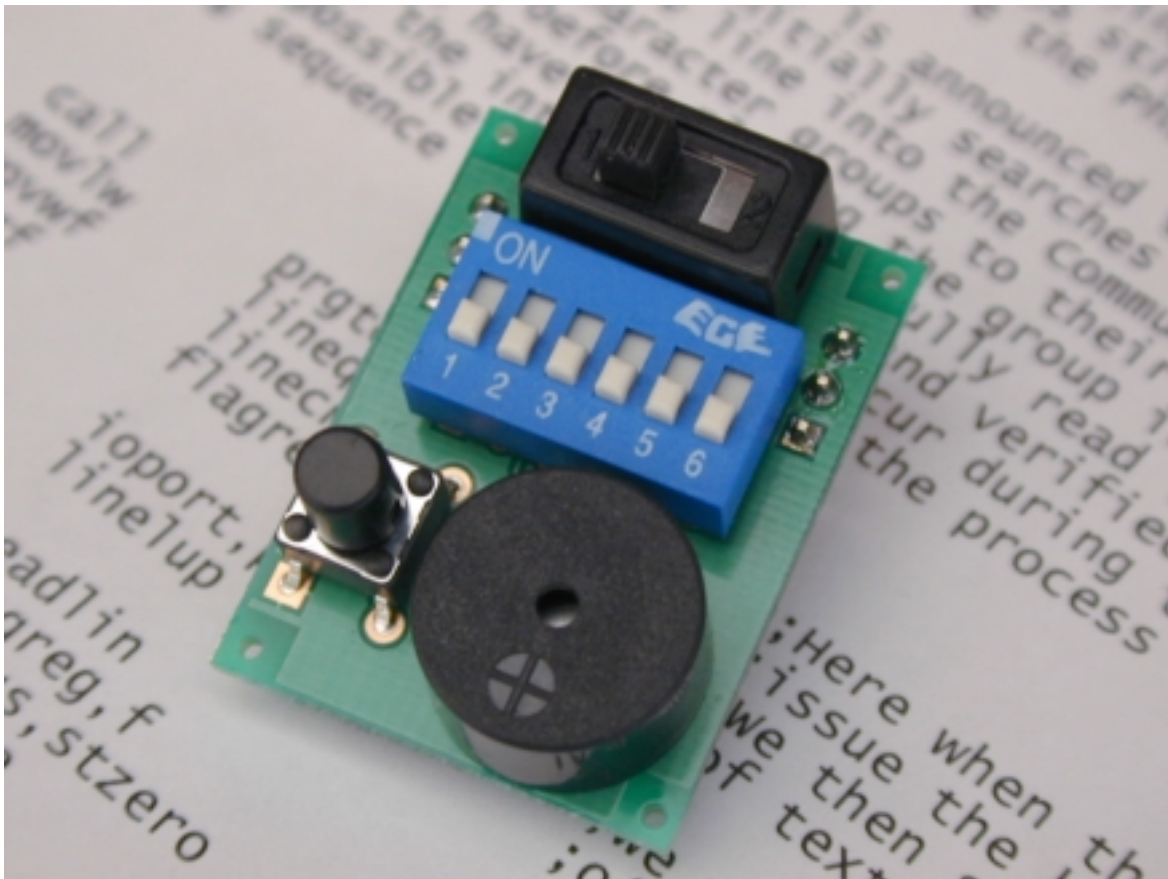

## User Manual

---

## Table of Contents

Heading	Page
Table of Contents	I F C
Introduction	1
Flight Mode	2
Glide Phase Timing	2
In-Flight Safety Features	3
Programming Mode	3
Default Settings	4
The Flight Control System	5
Power Supply	5
Electronic Speed Controller	5
De-Thermaliser Servo	5
Connecting Up	6
Power-Up Sequence	6
Wiring Diagram	7
PCB Component Layout and Mechanical Details	7
Specification Table	8
Phase Timing and Signal Table	8
Acknowledgement	8
DIP Switch Settings Table	I B C

## Introduction

FlytProf-Lite is a small, self-contained and simple-to-operate microprocessor based unit designed to provide electric free-flight modellers with a means of controlling an aircraft's flight profile. It operates as the central, controlling element of a Flight Control System by stepping through a pre-programmed sequence of timed Phases and, for each Phase, provides two standard R/C servo drive outputs.

The first of these is intended to drive an external motor speed controller [ESC] to provide power control and the other, connected to a servo, provides the 'de-thermaliser' [DTS] function.

FlytProf-Lite enables simple flight profiles to be implemented by providing 4 active Phases known as Launch, Power, Glide and Landing and two of these, the Power and Glide Phases, have user-programmable parameters – see the Phase Timing and Signal Table section.

The Power Phase has programmable ESC drive and Duration parameters and a fixed DTS drive while the Glide Phase provides fixed ESC and DTS drives but offers a programmable Duration. Setting of the three programmable parameters is achieved by means of an on-board 6-way DIP switch and timed push-button presses and, once entered, the flight profile program is stored in non-volatile memory [NVM] ready for immediate use on the flying field.

There is no practical limit to the number of times the parameters may be re-programmed.

FlytProf-Lite has two operating modes, known as Flight and Programming. Selection of the operating mode and control of the unit in each mode is performed by the board mounted push-button with acoustic feedback provided by the on-board buzzer.

FlytProf-Lite may be identified within the FlytProf family by the black push-button.

## Flight Mode

Powering-up FlytProf-Lite without pressing the push-button causes it to enter Flight Mode in a Pre-Launch state. In this condition the ESC drive is set to 1.00ms – in order to 'arm' the speed controller – and the DTS drive is set to its in-flight position of 1.00ms. The buzzer emits a continuous sound indicating that the unit is waiting for the push-button to be pressed.

Momentarily pressing the push-button causes FlytProf-Lite to enter the Launch Phase in which it ramps up the motor speed to its programmed value. Once the motor has reached its programmed speed FlytProf-Lite automatically enters the Power Phase and begins timing its Duration. Short 'ticks' are emitted by the buzzer at 1-second intervals confirming that the timing system is operating correctly.

On expiry of the timer, FlytProf-Lite enters the Glide Phase in which the motor is shut down and the duration timer is restarted with the programmed value. At the end of the Glide Phase the unit enters the Landing Phase and activates the DTS to bring the model down.

On recovery of the model the buzzer will be heard emitting 1-second 'ticks' indicating that the flight sequence completed normally.

To accommodate flights that end prior to the programmed duration pressing the push-button until a continuous sound is heard, and then releasing it, at any time during either the Glide or Landing phases cancels the current flight timing sequence and places FlytProf-Lite back into its Pre-Launch condition ready to enter a new Launch Phase.

This permits a new sequence to be started without the need to cycle the power.

## Glide Phase Timing

Although FlytProf-Lite's DTS output is primarily intended for controlling a de-thermaliser servo it may be re-assigned to any control-surface trimming function and, to provide timing flexibility for these alternative uses, the Glide Phase Duration is programmable with two resolutions.

Settings in the first section of the DIP Switch Settings Table offer timings of

between 1 and 15 seconds in 1-second steps while the remaining 3 sections permit Glide Duration values from 20 seconds to 255 seconds (4.25 minutes) in 5-second increments to be programmed.

*NOTE: contrary to typical mechanical timers in which all timers are started at launch, FlytProf-Lite starts timing the Glide Phase at the expiry of the Power Phase. Thus, for the normal application, a setting of 10 seconds for both phases results in a flight lasting for 20 seconds.*

## In-Flight Safety Features

FlytProf-Lite has two safety features built in to its program. The first of these is a battery voltage detection system which, in the event of a significant dip in supply voltage during a flight, causes the unit to re-enter its Pre-Launch condition shutting down the motor .

On recovering the model the activation of this mechanism may be determined by a continuous tone being emitted from the buzzer rather than the normal 1-second 'ticks'.

The second safety feature detects a stuck pushbutton. At the end of the Power Phase the pushbutton is checked and if it is found to be 'pressed' the unit immediately enters a Safety Phase shutting down the motor and setting the DTS output to bring the model down.

The buzzer issues a buzzing sound to indicate that this mechanism has been triggered and the power must be switched off to cancel this condition.

## Programming Mode

Holding the push-button pressed while powering-up causes FlytProf-Lite to enter Programming Mode, which it confirms by emitting 3 short 'beeps' from the buzzer. Releasing the push-button causes the buzzer to emit a continuous sound indicating that the unit is waiting for a button press. It is in this 'idle' state that the DIP switch may be set to determine the value of the parameter to be programmed – see the DIP Switch Settings Table.

Once the DIP switch has been set, the programming sequence is started by

pressing and holding the push-button. This immediately silences the buzzer, which then starts emitting a sequence of three 1-second long 'silences' followed by 1-second long 'beeps' – indicating the three programming slots. Releasing the button during one of the three 1-second 'beeps' determines which of the parameters is to be programmed:-

1. Motor Speed Pulse Width            in ms
2. Power Phase Duration                in seconds
3. Glide Phase Duration                in seconds – see DIP Switch Settings table

Confirmation of programming is indicated by the emission of two short 'beeps' and FlytProf-Lite then returns to its idle state, with the buzzer sounding continuously, waiting for a push-button press to initiate programming of the next parameter.

Any, or all, of the parameters may be programmed as many times as required during each programming session.

*NOTE: the programming sequence is cyclic and so, if the intended programming slot is missed, then simply keeping the push-button pressed until the appropriate slot in the next cycle will program the unit correctly. The start of a new programming cycle is indicated by an extended period of silence.*

To exit Programming Mode switch off the power when FlytProf-Lite is in its idle state and emitting a continuous sound.

## Default Settings

FlytProf-Lite is shipped with a set of default parameter values as indicated by the shaded area of the DIP Switch Settings Table. These provide a modest power setting and short Phase durations and are suitable for initial land-based testing.

They may be restored, as a set, at any time by setting the DIP switch to the all-zeros code and programming any one of the 3 Phase Parameters. Confirmation that the default values have been successfully restored is indicated by the buzzer emitting 4 short 'beeps' rather than the usual two.

## The Flight Control System

### Power Supply

The Flight Control System is powered by the Battery Eliminator Circuit [BEC] within the ESC – see the Specification Table section. Using this method the flight-pack voltage is reduced within the ESC to about 5V and is typically provided on the central pin of its servo-lead connector.

The FlytProf-Lite PCB is wired to route this supply via the Power Switch to the on-board electronics and to the central pin of the DTS connector. Thus the flight-pack provides power for the entire Flight Control System saving the weight and bulk of a separate pack.

*NOTE: in order to prevent possible erratic operation in flight, it is important to verify, by means of ground-based testing, that the BEC can provide enough current to drive the DT Servo under worst case battery and load conditions.*

### Electronic Speed Controller

The choice of ESC is not critical and may be selected from the available range based on the preferred motor type, brushless or otherwise, and power rating. It must be capable of accepting the standard R/C servo control signal of a 20ms frame containing a 1-2ms positive-going pulse and interpreting a pulse width of about 1.00ms as zero power and a pulse width of about 2.00ms as full power.

Additionally, it must be verified that its on-board BEC can provide enough current to drive the chosen DT Servo and that it will operate successfully from the desired flight-pack voltage – some ESCs place a limit on the maximum number of flight-pack cells if their on-board BEC is to be used.

### De-Thermaliser Servo

The selection of DT Servo is also not critical and should be based on the weight and power requirement of the model. During a typical flight the DT Servo is idle for most of the time, operating for only a second or so toward the end to bring the model down, and thus its overall power requirements are very low. However, it is at the end of a flight that the battery pack is at its lowest charge and so selecting a low-current servo will reduce the risk of control system failure due to battery voltage droop.

## Connecting Up

Two non-polarised, 3-pin male connectors compatible with standard servo leads are fitted to the rear face of the PCB. They are identified by the acronyms 'ESC' and 'DTS' and are intended for connection to the Electronic Speed Controller and De-Thermaliser Servo respectively.

Connection orientation is indicated on the PCB by means of an irregular outline corresponding to the shape of a typical servo lead plug and the pin assignments of each of these 3-pin connectors conforms to the standard "0V : 5V : Signal" adopted by Futaba, JR, Hitec etc. – see PCB Component Layout.

It is recommended that a device for isolating the battery is included in the wiring harness, as shown on the Wiring Diagram, and using a suitably rated two-part connector will also provide a convenient connection point for recharging the flight-pack.

## Power-Up Sequence

Before making the battery connection ensure that FlytProf-Lite's Power Switch is in the Off position. Once the battery is connected the Flight Control System may be powered-up by moving the Power Switch to the On position.

Follow the reverse procedure to power the system down.

## Wiring Diagram

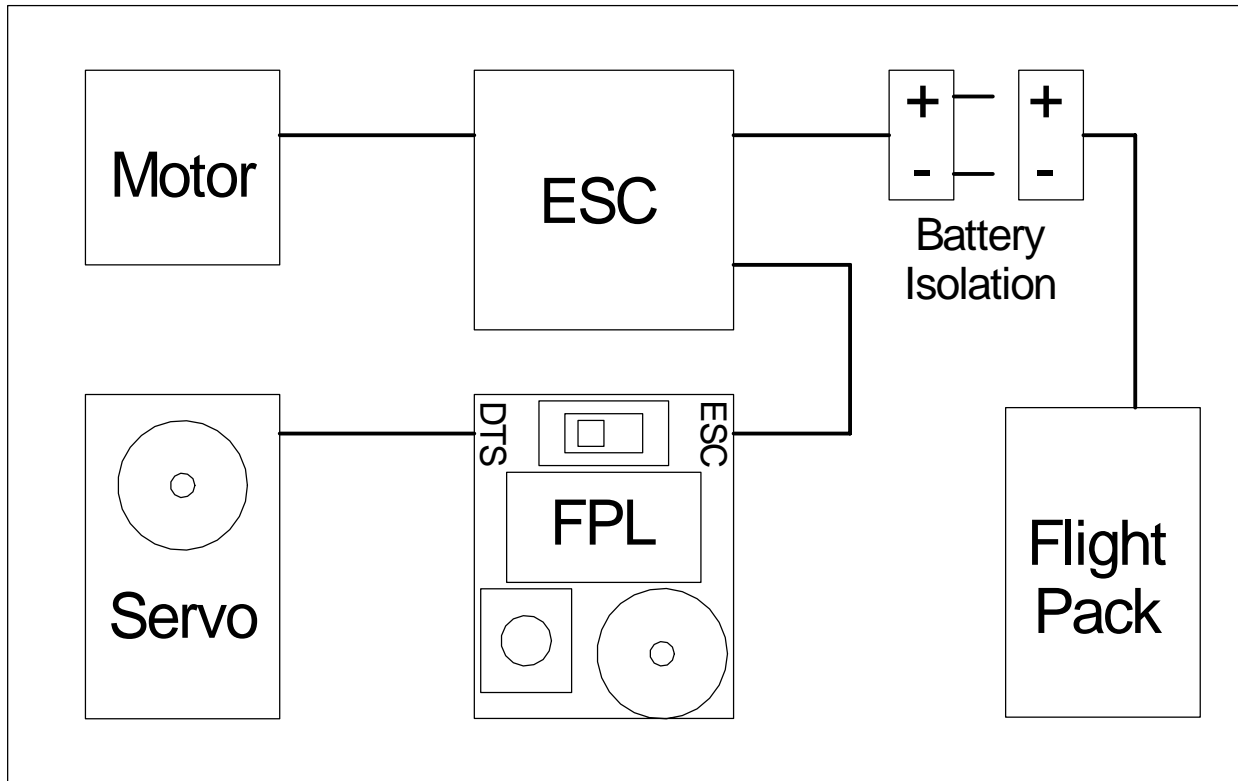

## PCB Component Layout and Mechanical Details

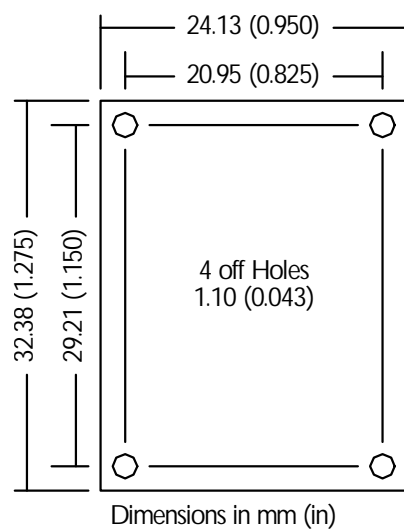
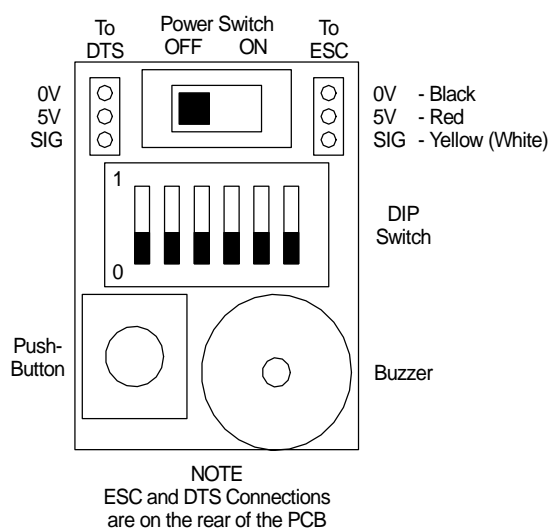

## Specification Table

Parameter	Min	Typ	Max	Units	Comment
Supply Voltage	4.5	5.0	6.0	Volts	Provided by ESC BEC function
Supply Current			1.5	mA	No external loads
ESC & DT Servo Pulse Width Range	1.00		2.00	ms	
ESC & DT Servo Pulse Amplitude	4.0		5.0	Volts	No external loads

## Phase Timing and Signal Table

Phase	Parameter	Min	Typ	Max	Units	Comment
Pre-Launch (or Idle)	Duration	N/A				Determined by user with push-button
	ESC Drive pulse width	0.98	1.00	1.02	ms	Fixed
	DT Servo pulse width	0.98	1.00	1.02	ms	Fixed
Launch	Duration	0.02		1.28	sec	Determined by Motor Speed setting
	ESC Drive pulse width	1.00		2.00	ms	Ramps up to programmed value
	DT Servo pulse width	0.98	1.00	1.02	ms	Fixed
Power	Duration	1		63	sec	Programmable in 1 second steps
	ESC Drive pulse width	1.04		1.97	ms	Programmable in 63 equal steps
	DT Servo pulse width	0.98	1.00	1.02	ms	Fixed
Glide	Duration	1		255	sec	See DIP Switch Settings table
	ESC Drive pulse width	0.98	1.00	1.02	ms	Fixed
	DT Servo pulse width	0.98	1.00	1.02	ms	Fixed
Landing	Duration	N/A				
	ESC Drive pulse width	0.98	1.00	1.02	ms	Fixed
	DT Servo pulse width	1.98	2.00	2.02	ms	Fixed

*NOTE: all specification and timing values assume a nominal supply voltage of 5V.*

## Acknowledgement

Thanks are due to Ian Middlemiss of Peterborough Model Flying Club for providing the original idea for the FlytProf free-flight controller range and also for his considerable efforts and guidance during the development and testing of this product.



# The Model Electronics Company

The Model Electronics Company  
68 Kentsford Road  
Kents Bank  
Grange-over-Sands  
Cumbria  
LA11 7BB  
United Kingdom

<http://www.omegaco.demon.co.uk/mechome.htm>