

## Dual Output Pseudo-Random Noise Generator

### Features

- Two Independent Outputs
- Separate O/P Control Signals
- Programmable Control Sense
- 23-bit L.F.S.R. Design
- Broad Output Spectrum
- High Level Signal Output

### Applications

- Sound Synthesisers
- Electronic Organs
- Steam Sound Generators
- Bi-plane Sound Generators
- Acoustic Equalisation Systems

### Pin Diagram

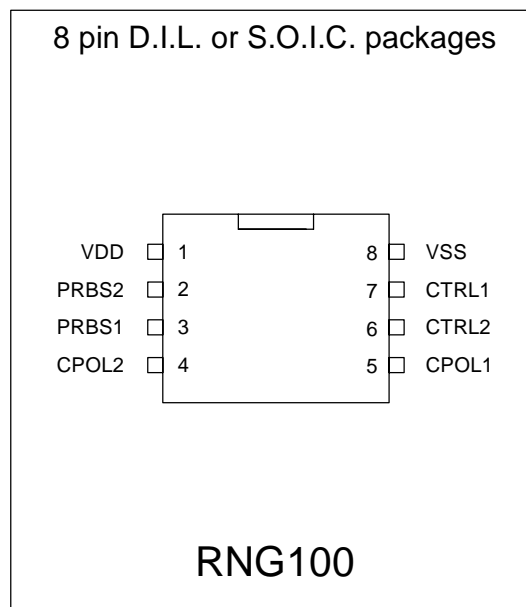

### General Description

The RNG100 Pseudo-Random Noise Generator consists of two identical independent Pseudo Random Bit Sequence (PRBS) generators each producing a broad frequency spectrum output. The output signal from each generator (PRBSx) may be individually enabled or disabled by the logic level present on the Control pins (CTRLx). In order to provide maximum flexibility the sense of the Control signals is individually programmable by means of the logic levels present on the Control Polarity inputs (CPOLx)

Each of the RNG100 PRBS outputs produces a signal with a fundamental frequency spectrum extending from below 3mHz to over 22kHz with the harmonics of the output waveform extending the upper frequency well into the MHz region. Because the output signal amplitude is large, the pk-pk value approaching the magnitude of the power supply, a useful signal can still be obtained after some post-output filtering has been applied.

## Absolute Maximum Ratings

Supply Voltage ( $V_{CC}$ )	0 to +7V
Max. Voltage on I/O pins	-0.5V to ( $V_{CC}+0.5V$ )
I/O Pin Clamp Current	$\pm 20mA$
Output Source Current (single pin)	-25mA
Output Source Current (total on all pins)	-75mA
Output Sink Current (single pin)	+25mA
Output Sink Current (total on all pins)	+75mA
Total Power Dissipation	500mW
Operating Ambient Temperature Range	0°C to 70°C
Junction Temperature	150°C
Storage Temperature Range	-65°C to 150°C
Lead Temp. during Soldering (10sec)	300°C

**NOTES:**

Exceeding the values in this table may impair or destroy the device. Currents with a negative sign are said to flow out of the device. All voltages are measured with respect to the  $V_{SS}$  pin.

## Package Availability

The RNG100 is available in an 8 pin 0.3" (7.62mm) Dual-in-Line (DIL) package. See Package Data for details.

## Package Data

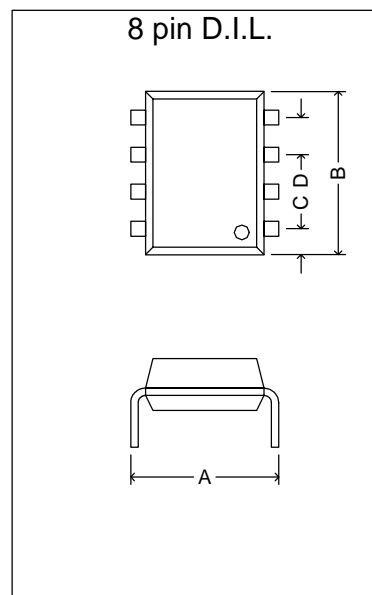

Dimension		in	mm
Pin Width	A	0.30	7.62
Length	B	0.38	9.65
Pin Offset	C	0.04	1.00
Pin Pitch	D	0.10	2.54

## Pin-out Description

Pin No.	Name	Type	Description
1	VDD	P	Positive power supply pin for internal logic and I/O pins
2	PRBS2	O	Output signal - PRBS Generator 2
3	PRBS1	O	Output signal - PRBS Generator 1
4	CPOL2	I	Control Signal Polarity - PRBS Generator 2
5	CPOL1	I	Control Signal Polarity - PRBS Generator 1
6	CTRL2	I	Control Signal - PRBS Generator 2 On/Off control
7	CTRL1	I	Control Signal - PRBS Generator 1 On/Off control
8	VSS	P	Ground reference supply pin for internal logic and I/O pins

## Detailed Description

### Overview

The RNG100 Pseudo-Random Noise Generator IC is a pre-programmed micro-controller product based on the Arizona Microchip PIC12C508-04P device and, as such, shares the same basic electrical characteristics.

The noise it produces is characterised by a broad frequency spectrum and is similar to the sound produced by a FM radio when tuning between stations with the mute function disabled and is thus a 'hissing' sound. This is referred to as 'white noise'.

It is intended to be used with external circuitry to provide signal output gating control and any appropriate post-output circuitry. Suitable post-output circuits may include attenuators, filters and possibly mixers.

The RNG100 consists of two independent noise generators each based on a Maximal Length 23-bit Linear Feedback Shift Register and so provides a complete cycle with over 8 million distinct states. The device makes use of the internal 4MHz oscillator producing a device instruction time of 1us. The two LFSRs are constructed using 23-bit registers shifted by the program execution and, as the program 'loop time' is 44us, each LFSR is shifted every 44us leading to a total cycle time of about 370s or approximately 0.0027Hz.

A special feature of a PRBS is that, due to its randomness, it possesses no particular bias to one logic level or the other within its cycle time. This gives it the characteristic of having 'zero offset' around its mid-point. This feature can be utilised, when used in conjunction with an AC coupling circuit, to produce essentially 'click-free' output on/off transitions.

### Output Control

Each of the two generators has an output gating facility (CTRLx) that permits on/off control of its output signal. When an output is set to the 'on' state the PRBSx pin presents the current state of the Least Significant Bit (LSB) of its LFSR. When set to 'off' the PRBSx output is disabled and floats. Disabling an output does

not disable its respective generator which continues operating in the normal way.

In order to maximise the flexibility of the RNG100 the sense of each of the CTRLx signals is programmable. This is accomplished by the setting of the logic level on the Control Polarity (CPOLx) pin. The following table gives the relationships between output states and the control inputs.

CTRLx	CPOLx	PRBSx
0	0	ON
0	1	OFF
1	0	OFF
1	1	ON

### White Noise and the L.F.S.R.

The following paragraphs give a brief resume of White Noise and the Linear Feedback Shift Register.

#### White Noise

White noise possesses the characteristic that its amplitude rises by +3dB for every octave (a frequency ratio of two) rise in frequency. This produces a constant amount of energy in a given bandwidth or, put another way, the energy contained in any 'frequency slot' with a given width is the same. The LFSR generates white noise because it produces a pseudo-random bit sequence at its output. In simple terms this means that although the output can only be in either of two states, a logic 0 or 1, the length of time that each state is held, before changing to the opposite state, is 'random'.

#### The L.F.S.R.

The LFSR, which is also sometimes known as a polynomial counter or pseudo-random counter, is basically a shift register fabricated from a number of bi-stables connected output-to-input in a chain like fashion. At two, or more, points along the chain the states are extracted and gated together to produce the next input state and thus a continuous 'loop' is formed.

The LFSR is known a 'pseudo-random' counter because it does not generate a truly random output. Because the input state is produced by a selection from the current state according to a set of rules, as described above, there will come a time when the pattern repeats. The rate

at which the pattern repeats is called the 'cycle time'.

An ordinary binary counter has  $2^n$  possible states which, for a 4 bit counter, is 16 ( $2^4 = 16$ ). The LFSR can almost match this with  $2^n - 1$  states, i.e. 15 for a 4 bit counter. The reason for the 'missing' state is that LFSR counters suffer from an inherent problem in that the last state, known as the 'stuck state' is not available for use.

The following diagram shows a simple 9 stage LFSR which has the feedback signal generated from the 5<sup>th</sup> and 9<sup>th</sup> stages and is, therefore, a maximal length counter for this number of stages.

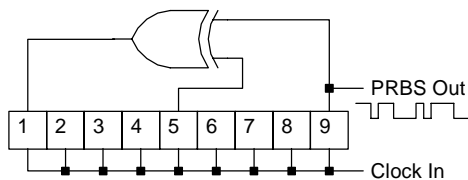

Simple Linear Feedback Shift Register

P.R.B.S. Output Frequency Spectrum

The frequency spectrum of the signal produced by the LFSR extends down to the period of its cycle time and is written as:

$$\frac{F_{clock}}{K}$$

$F_{clock}$  = clock frequency.  
 $K$  = No. of states.  
 This frequency may be called the 'base frequency'.

The upper part of the spectrum extends to the clock frequency.

The spectral content is made up of a series of discrete frequencies separated by the base frequency. In the RNG100 the base frequency is so low at 2.7mHz that, for all intents and purposes, the spectrum may be considered continuous.

The spectrum is flat to within 3dB up to a frequency equal to:

$$\frac{F_{clock}}{2.27}$$

This frequency may be called the 'upper frequency'.

In the RNG100 this represents a frequency of exactly 10kHz and the response falls off rapidly above this -3dB frequency. The entire response envelope may be expressed using the following equation:

$$\left( \frac{\sin \left( \frac{\pi F}{F_{clock}} \right)}{\frac{\pi F}{F_{clock}}} \right)^2$$

The power contained in the output spectrum has fallen to zero at the clock frequency.

Block Diagram

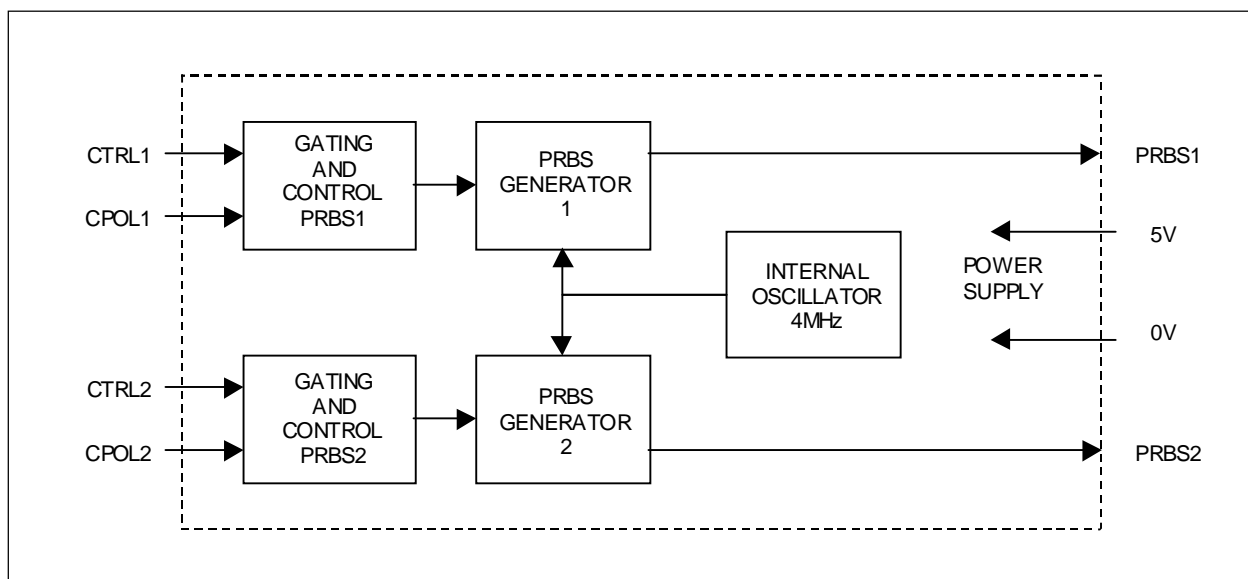

# Test Circuit and Waveforms

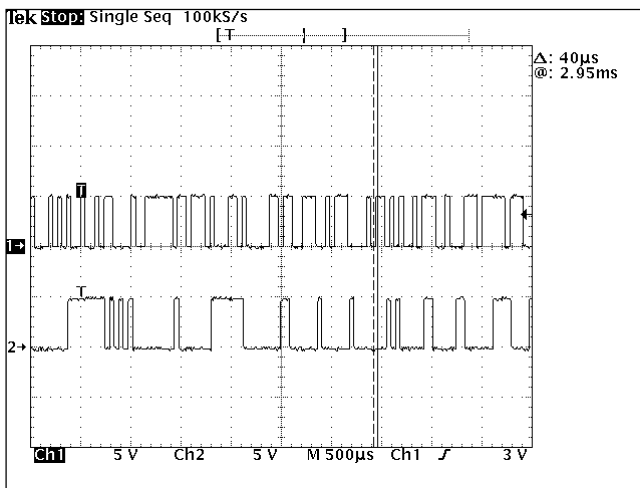
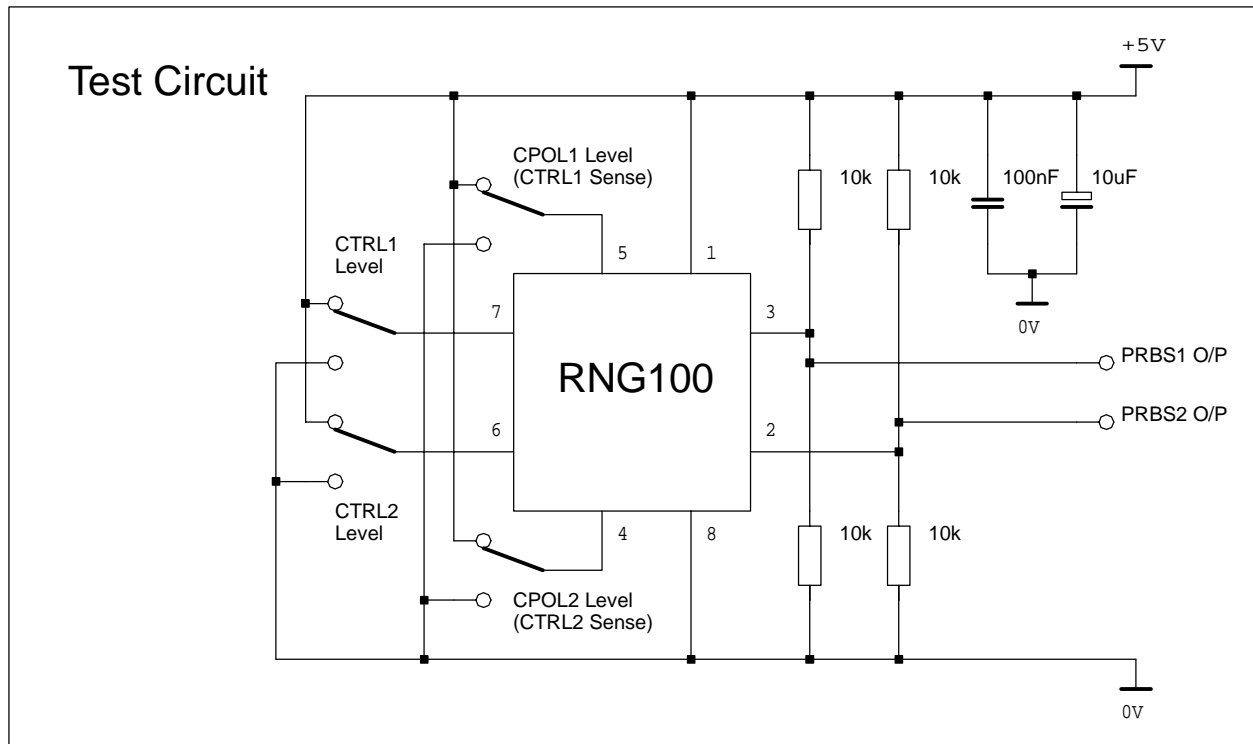

Figure 1

Figure 1 shows both outputs of the RNG100 in the active state. Both are producing PRBS signals that show no correlation one with respect to the other. The cursor bars are set to span a single 'bit time' and measure about 44µs which demonstrates the program loop time.

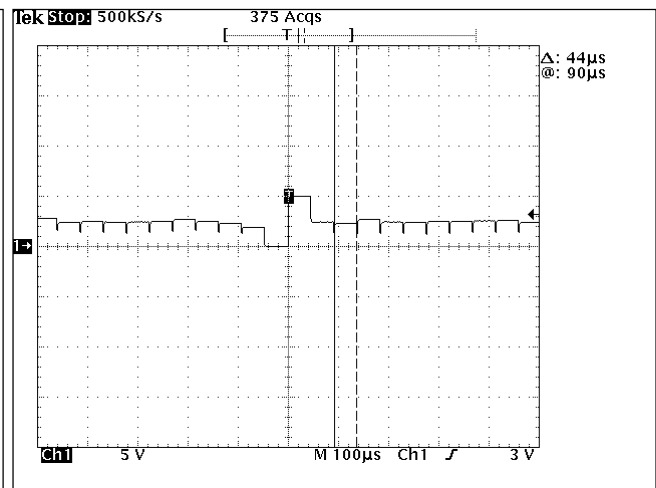

Figure 2

Figure 2 shows the short-term signal around the oscilloscope trigger point with the oscilloscope set to average over many acquisitions. This shows the nominally zero DC content to the PRBS signal and is a measure of its short-term randomness. (Note that the small 'spikes' contain very little energy and are due to a software process setting a logic 0 output level 2µs earlier than it would set a logic 1 level.)

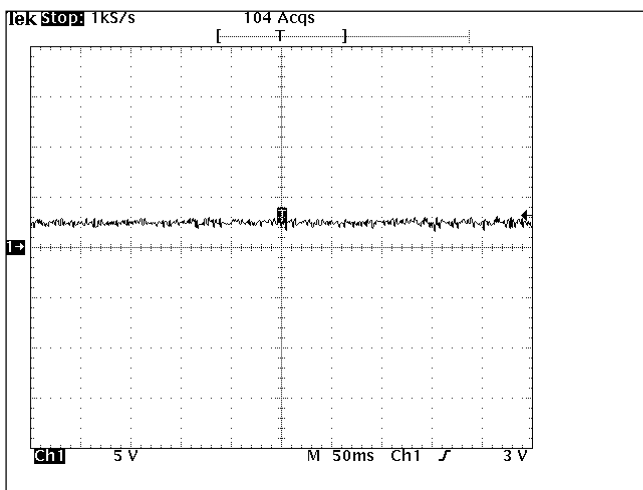

Figure 3

Figure 3 shows the long-term signal around the oscilloscope trigger point with the oscilloscope set to average over many acquisitions. This shows the nominally zero DC content to the PRBS signal and demonstrates good long-term randomness.

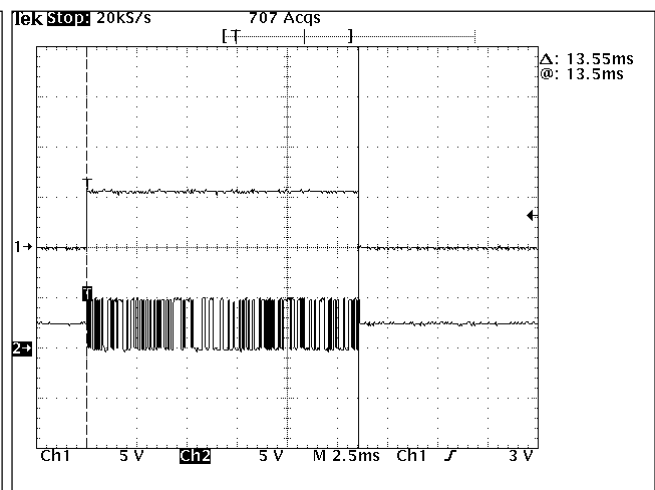

Figure 4

Figure 4 depicts the action of the PRBS output signal on/off control. The upper trace is provided by a pulse generator and drives the CTRL1 pin. Using this capability enables a wide range of intermittent sounds to be produced.

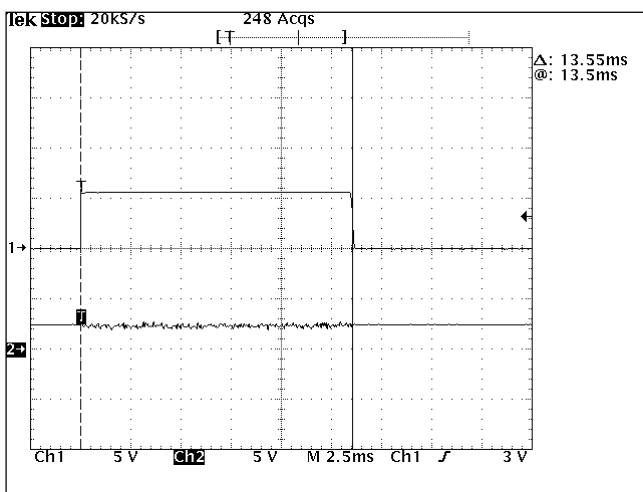

Figure 5

Figure 5 depicts the gated PRBS signal, as Figure 4, but with the oscilloscope averaging enabled. This clearly shows both the inactive and active states of the PRBS output and also that, during the active period, the nominal DC level is the same as for the inactive state. (Note that when the PRBS output is inactive the DC level present on the output pin is set by the 10k resistors shown in the Test Circuit above).

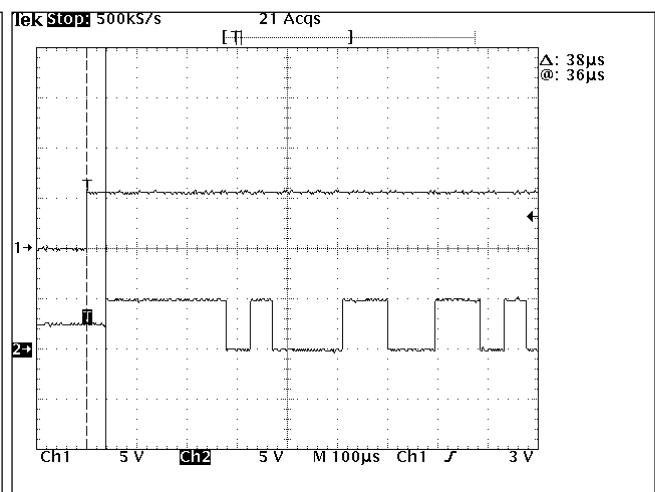
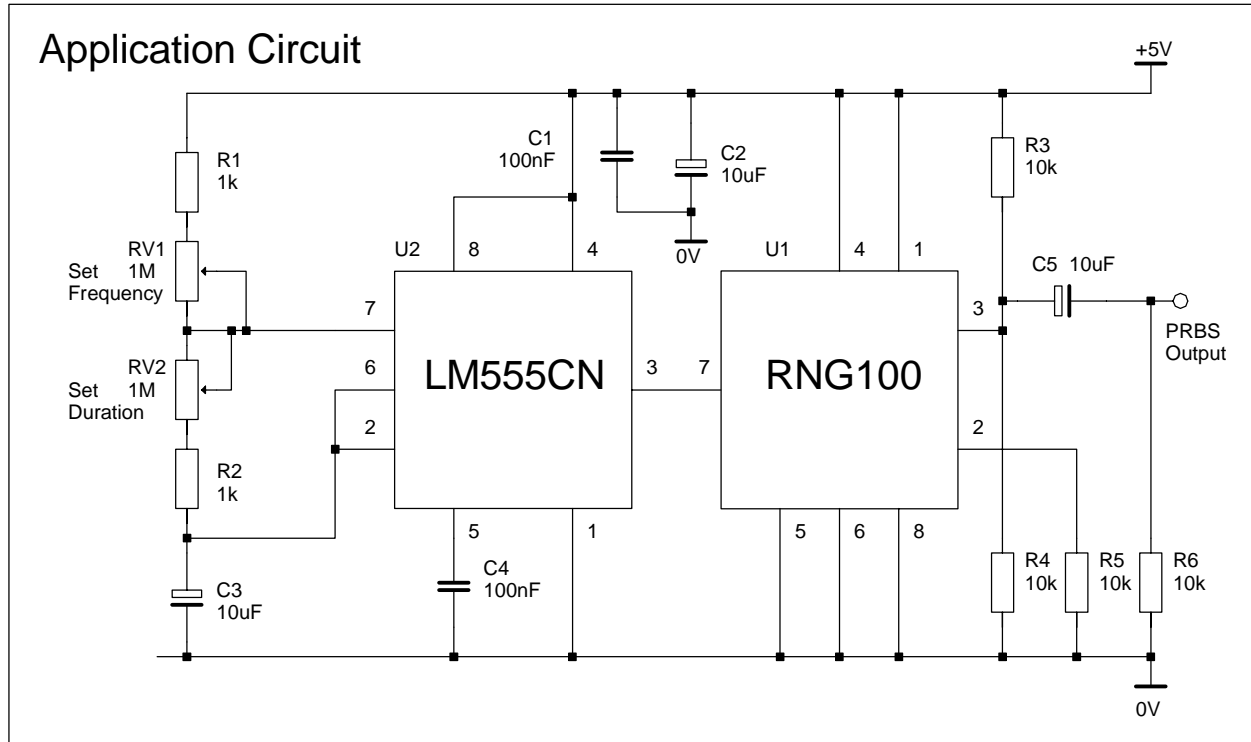

Figure 6

Figure 6 shows a typical RNG100 response time to the CTRLx signal going active. The delay is measured by the cursors at 38us. The delay incurred at the inactive edge is similar but, due the asynchronous nature of the control signal, it will not necessarily be the same.

## Application Information and Hints



The application circuit above gives details of a schematic suitable for experimenting with the RNG100. The LM555CN is wired as a low frequency astable oscillator, with both the period and mark/space ratio adjustable using RV1 and RV2 respectively, and is connected such that it enables the RNG100 PRBS output signal during the time its output signal is at a logic 0 level.

For more details on the LM555CN please see the data sheet from National Semiconductor.

The application circuit shown only makes use of PRBS channel 1 and sets channel 2 to its inactive state. A similar drive circuit using another LM555CN, or possibly the LM556CN dual version, could be added to make experiments with both channels possible.

### PRBS Burst Frequency

The action of the LM555CN is to gate the PRBS output on and off at a rate set by RV1 in conjunction with RV2. Assuming that RV2 is set to value considerably less than RV1 its contribution to the output frequency is small.

The full output frequency range extends from approximately 0.05Hz up to about 100Hz

### PRBS Burst Duration

The duration that the PRBS output is active is set by RV2 and is adjustable from about 7ms to about 7s.

### Listening to the Output Signal

It is very instructive to listen to the PRBS signal using a small loudspeaker as adjustment of the two variable resistors enables a wide variety of sounds to be produced.

A suitable attenuator to reduce the signal level to a value safe for use with low-impedance headphones is shown in the diagram below:

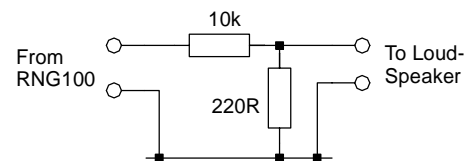

Loudspeaker Attenuator

Output Signal Amplitude

The PRBS signal present at the output is a 5V pk-pk 'square wave' form centred on 0V. The amplitude may be attenuated by connecting a suitable resistor network, similar to that shown above, across R6. To prevent exceeding the RNG100 output current ratings the attenuator impedance should be kept above 500R.

Pink Noise

There is a variation of white noise known as 'pink noise'. It is characterised by a falling amplitude response, at -3dB per octave, and thus possesses equal energy per octave. It may be synthesised from white noise by means of a special filter. One such filter, extracted from a National Semiconductor data book, is shown below. It produces a pink noise signal of about 0.5V pk-pk when connected to a RNG100 PRBS output.

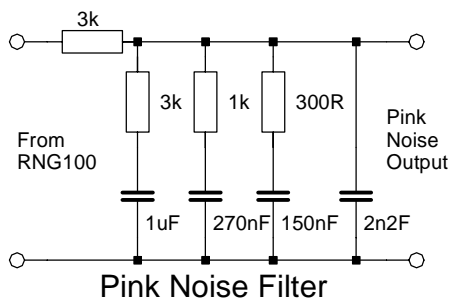

Notes

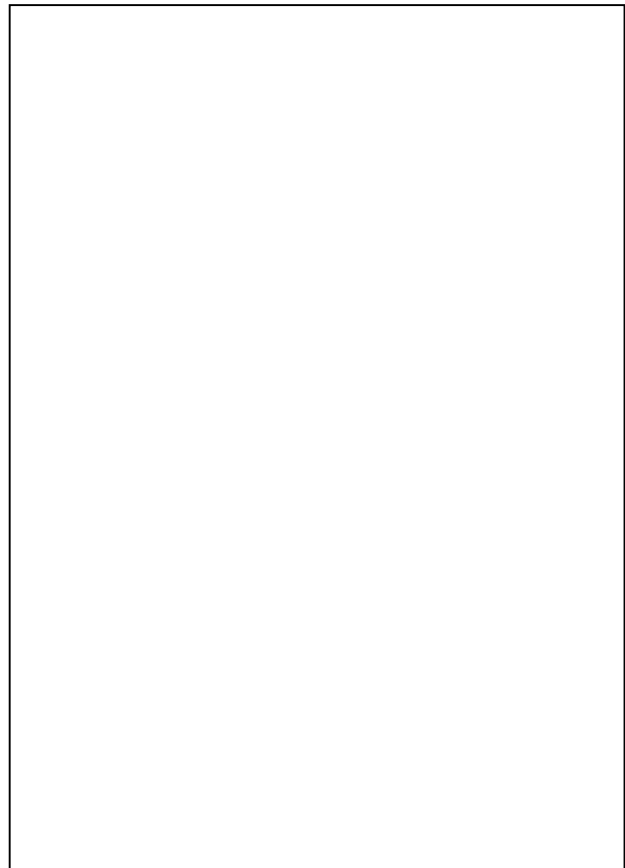

This datasheet is issued by :-

The Model Electronics Company  
 68 Kentsford Road  
 Grange-over-Sands  
 Cumbria LA11 7BB

For information on placing an order for this product please see our price list which gives details of prices and payment methods. The price list may be obtained from the address above or from our web-site.

<http://www.omegaco.demon.co.uk/mechome>

© The Model Electronics Company